

MSCI OVERSEAS CHINA INDEXES METHODOLOGY

November 2018

CONTENTS

- 1 Introduction 3
- 2 Index Construction 4
 - 2.1 Defining the Eligible Equity Universe 4
 - 2.2 Determining the Investable Equity Universe 4
 - 2.3 Allocating Companies into Size-Segment Index..... 5
- 3 Index Maintenance 6
 - 3.1 Index Review 6
 - 3.1.1 Cutoff Date for Market Capitalization and Prices Used for the Index Reviews 6
 - 3.1.2 November and May Semi-Annual Index Reviews6
 - 3.1.3 February and August Quarterly Index Reviews7
 - 3.1.4 Buffer Rules.....7
 - 3.1.5 Policy Regarding Trading Suspensions for Individual Securities During Index Reviews 8
 - 3.1.6 Announcement Policy9
 - 3.2 Ongoing Event-Related Maintenance 9
 - 3.2.1 IPOs and Other Early Inclusions9
 - 3.2.2 Changes in Size-Segment Classification as a Result of a Large Corporate Event 10
 - 3.2.3 Deletion of Existing Constituents..... 10
- Methodology Book Tracked Changes 11

1 INTRODUCTION

The MSCI Overseas China Indexes are designed as standalone free-float adjusted market capitalization indexes that reflect the performance of securities of US and Singapore-listed overseas Chinese companies. The MSCI Overseas China Indexes are constructed with similar size and liquidity requirements as the MSCI China Investable Market Indexes with an aim to provide consistency between both index construction methodologies.

2 INDEX CONSTRUCTION

2.1 DEFINING THE ELIGIBLE EQUITY UNIVERSE

The MSCI Overseas China Indexes are free float-adjusted market capitalization indexes constructed using similar size and liquidity requirements as the MSCI China Investable Market Indexes under the MSCI Global Investable Market Indexes (GIMI) methodology. Equity securities (including ADRs) of overseas Chinese companies listed on the NYSE Euronext - New York, NASDAQ, NYSE MKT LLC (formerly NYSE AMEX) and Singapore Exchange are eligible for index inclusion.

Overseas Chinese companies are generally defined as companies that meet two out of three of the following criteria:

- The company’s headquarter is located in PRC
- The company derives more than 50% of its revenue from the PRC¹
- The company has more than 50% of its assets in the PRC¹

In some exceptional cases, an additional analysis may be performed to ensure the company meeting the above criteria has a sufficient linkage to China. The outcome of this analysis may lead to some companies not being eligible for the MSCI Overseas China Indexes despite meeting two out of three of the criteria above.

US -listed companies resulting from reverse mergers² and Singapore-listed companies that are currently in the SGX’s Watch List³ are not eligible for index inclusion.

2.2 DETERMINING THE INVESTABLE EQUITY UNIVERSE

To be eligible for index inclusion, securities of companies must conform to the size and liquidity requirements applied to the MSCI China Indexes under the MSCI GIMI methodology at the time of index review⁴. Specifically, a security should fulfill the minimum full company

¹ Only revenue and asset attributed to PRC will be taken into account in this calculation. For cases where the distribution to PRC is bundled with other regions, only distribution to PRC and Hong Kong will be counted.

² This criterion has been introduced to mitigate the risk of including index constituents that may not be in compliance with US accounting standards and regulatory filings.

³ Singapore-listed companies will be put on SGX’s Watch List if they register both of these two conditions: 1) pre-tax losses for the three most recently completed consecutive financial years; and 2) an average daily market capitalization of less than S\$40 million over the last 120 market days on which trading was not halted or suspended for the full day.

⁴ As of the May 2014 Semi-Annual Index Review, the minimum full company market capitalization and free float-adjusted market capitalization requirements are USD 196 million and USD 98 million, respectively.

market capitalization and free float-adjusted market capitalizations requirements that are applied to the MSCI China Index. A security must have a Foreign Inclusion Factor (FIF) equal to or larger than 0.15, except for large securities⁵. In addition, a security must have a 12-month ATVR of at least 15%, a 3-month Annualized Traded Value Ratio (ATVR) of at least 15% and a 3-month frequency of trading of at least 80% over the last 4 consecutive quarters. A minimum of three-month seasoning period will be applied to all newly issued securities.

2.3 ALLOCATING COMPANIES INTO SIZE-SEGMENT INDEX

The Investable Equity Universe is segmented into the following size-segment indexes:

- Investable Market Index (IMI) (Standard + Small Cap)
- Standard Index (Large Cap + Mid Cap)
- Large Cap
- Mid Cap
- Small Cap

The MSCI Overseas China Size-Segment Indexes follow identical Size-Segment Cutoffs as the MSCI China Size-Segment Indexes. All securities with full company market capitalization equal to or larger than the Size-Segment Cutoff are pre-assigned to that size-segment index.

For a security that is eligible for the Standard Size-Segment to be added to the MSCI Overseas China Standard Index, its free float-adjusted market capitalization must be at least 50% of the Size-Segment Cutoff for the MSCI China Index. For a security that is eligible for the Small Cap Size-Segment to be added to the MSCI Overseas China Small Cap Index, its free float-adjusted market capitalization must be at least 50% of the Size-Segment Cutoff for the MSCI China Investable Market Index.

For a security with a FIF lower than 0.15 to be included in the MSCI Overseas China Index, including migrations from the MSCI Overseas Small Cap Index, its free float-adjusted market capitalization must be at least 1.8 times the minimum free float-adjusted market capitalization required for the Standard Index.

⁵ Large securities are defined as securities with a company full market capitalization that meet at least 1.8x the MSCI China Interim Market Standard Size-Segment Cutoff and a free float-adjusted market capitalization that meet at least 1.8x one-half of the MSCI China Interim Market Standard Size-Segment Cutoff.

3 INDEX MAINTENANCE

3.1 INDEX REVIEW

The MSCI Overseas China Indexes are reviewed on a quarterly basis. The composition of the MSCI Overseas China Indexes is fully reviewed once a year at the November Semi-Annual Index Review (SAIR). During the May SAIR, there may be migrations of current Investable Market Index constituents, and newly issued securities since the last SAIR are also considered for inclusion subject to meeting all eligibility requirements. IPOs of significant size are exceptionally considered during SAIRs even if they fail the seasoning criteria described in section 2.2 and the Early Inclusion criteria as described Section 3.3.1. For the February and August Quarterly Index Review (QIRs), there may only be migrations of current Investable Market Index constituents and no new security will be considered for index inclusion, with the exception of large IPOs.

Changes for the SAIRs are implemented as of the close of the last business day of May and November, whilst changes for the QIRs are implemented as of the close of the last business day of February and August.

3.1.1 CUTOFF DATE FOR MARKET CAPITALIZATION AND PRICES USED FOR THE INDEX REVIEWS

The cutoff date for market capitalization and prices used for the rebalancing of the MSCI Overseas China Indexes is as of the close of the respective announcement dates of the February, May, August and November Index Reviews.

3.1.2 NOVEMBER AND MAY SEMI-ANNUAL INDEX REVIEWS

During November SAIRs, existing constituents will be evaluated for their compliance with the definition of Overseas Chinese Companies. Existing constituents may remain in the eligible equity universe as long as they meet any two out of three of the following criteria:

- The company’s headquarter is located in PRC
- The company derives more than 33% of its revenue from PRC
- The company allocates more than 33% of its assets in PRC

In addition, existing constituents must satisfy the following minimum liquidity criteria to remain in the index:

- The 12-month ATVR of at least 10%
- The 3-month ATVR of at least 5%
- The 3-month Frequency of Trading of at least 70%

During the May SAIR, existing constituents are not evaluated for their compliance with the definition of Overseas Chinese Companies. Additionally, there may be migrations of current Investable Market Index constituents at both SAIRs.

In addition, newly issued securities (since the last SAIR up to the month prior to the Rebalancing of the MSCI OVC Index) are also considered for inclusion subject to meeting all eligibility requirements as outlined in Section 2. However, securities that fail to meet the seasoning criteria described in section 2.2 must, in addition to all the inclusion criteria detailed in Section 2 (except for the length of trading and liquidity requirements), have a company full market capitalization that meets at least 1.8x the MSCI China Interim Market Standard Size-Segment Index Cutoff and a free float-adjusted market capitalization that meets at least 1.8x one-half of the MSCI China Interim Market Standard Size-Segment Cutoff as of the rebalancing date for the MSCI Overseas China Index.

3.1.3 FEBRUARY AND AUGUST QUARTERLY INDEX REVIEWS

For the February and August QIRs, there may only be migrations of current Investable Market Index constituents and no new security will be considered for index inclusion. Existing constituents will not be evaluated for their compliance with the definition of Overseas Chinese Companies.

Existing constituents will be evaluated for index inclusion under the same investability requirements as outlined in section 3.1.1.

In addition, newly issued securities that failed to meet the Early Inclusion criteria as described in Section 3.2.1 (since the previous Index Review up to the month prior to the Rebalancing of the MSCI OVC Index), including those that fail the seasoning criteria described in section 2.2, may be re-evaluated for Early Inclusion at the following Index Review. To be added to the MSCI Overseas China Index at the Quarterly Index Review these securities must meet all the inclusion criteria detailed in Section 2 (except for the length of trading and liquidity requirements) and, in addition, must have a company full market capitalization that meets at least 1.8x the MSCI China Interim Market Standard Size-Segment Cutoff and a free float-adjusted market capitalization that meets at least 1.8x one-half of the MSCI China Interim Market Standard Size-Segment Cutoff as of the rebalancing date for the MSCI Overseas China Index.

3.1.4 BUFFER RULES

In order to better reflect the investment processes of managers, allow for timely representation of market developments when securities move far from size-segment thresholds, and help control index turnover, buffer zones are used to control the migration of companies between Size-Segment Indexes during Index Reviews.

An existing constituent is generally allowed to remain in its current size-segment even if its full market capitalization falls below (above) the Size-Segment Cutoff that defines the lower (upper) boundary of its segment, as long as its company full market capitalization falls within a buffer zone below (above) the Size-Segment Cutoff. In addition, its free float-adjusted market capitalization is at least two-thirds of 50% of the Size-Segment Cutoff for securities allocated to the Standard Index or the Small Cap Index. The buffer zones are defined with boundaries at -33% and +50% of the Size-Segment Cutoff between two size-segments for SAIRs and -50% and +80% of the Size-Segment Cutoff between two size-segments for QIRs.

Existing constituents of the MSCI Overseas China Index with FIF of less than 0.15 must have a free float-adjusted market capitalization of at least 1.8 times two-thirds of the minimum free float-adjusted market capitalization requirement for the Standard Index as defined in section 2.3. Existing constituents of the MSCI Overseas China Small Cap Index must have a FIF equal to or larger than 0.15 to remain in the Index.

In addition, a Small Cap Entry Buffer Zone is used for the entry in the Small Cap Indexes of non-current constituents. It is defined with a boundary at +50% the Market Size-Segment Cutoff for the Investable Market Index.

Buffers at index reviews

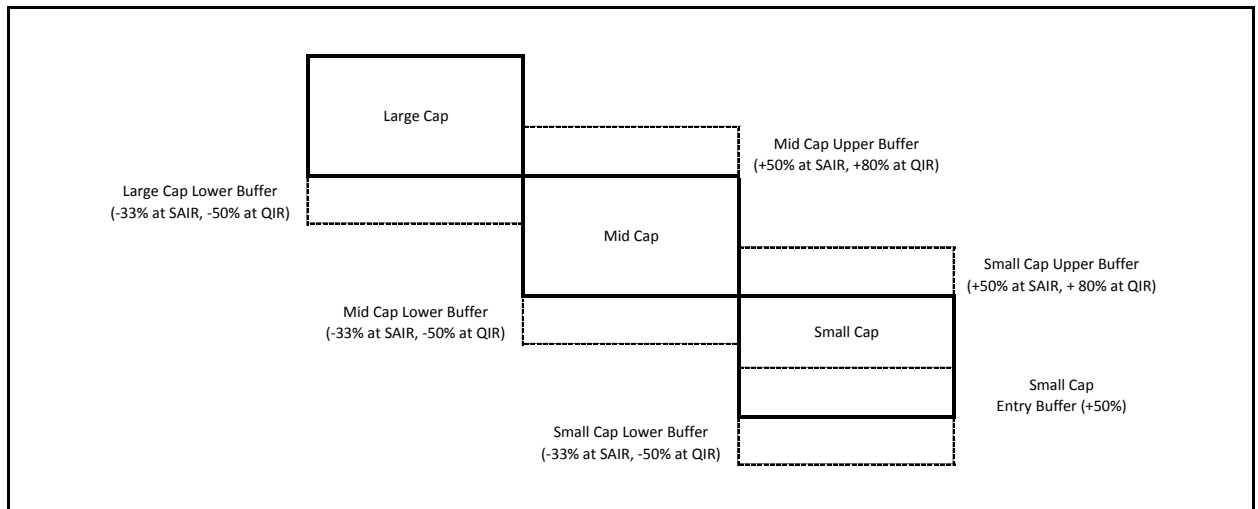

3.1.5 POLICY REGARDING TRADING SUSPENSIONS FOR INDIVIDUAL SECURITIES DURING INDEX REVIEWS

MSCI will postpone the implementation of index review changes for MSCI Overseas China Index constituents when the affected securities are suspended on the day prior to the

effective implementation date of the Index Review. The postponed index review changes will be implemented two days after the securities resume trading.

Index Review changes include:

- Additions to, deletions from or migrations between the MSCI Large Cap, Mid Cap and Small Cap Indexes
- Changes in Foreign Inclusion Factor (FIF) , Domestic Inclusion Factor (DIF) or Number of Shares (NOS) for current and pro forma index constituents of the MSCI Overseas China Indexes

All index review changes that are postponed due to suspension will be cancelled two months after the effective date of the Index Review if the securities are still suspended and will be implemented at the Index Review following the securities’ resumption of trading if still warranted.

3.1.6 ANNOUNCEMENT POLICY

The results of the index reviews are announced two days following the February, May, August and November quarterly index review announcement dates.

3.2 ONGOING EVENT-RELATED MAINTENANCE

Ongoing event-related changes to the Indexes are the result of mergers, acquisitions, spin-offs, bankruptcies, reorganizations and other corporate events. They can also result from capital reorganizations in the form of rights issues, bonus issues, public placements and other similar corporate actions that take place on a continuing basis. These changes generally are reflected in the indexes at the time of the event.

Details regarding the treatment of corporate events not covered below can be found in the MSCI Corporate Events Methodology Book, available at:

<http://www.msci.com/index-methodology>

3.2.1 IPOs AND OTHER EARLY INCLUSIONS

Securities with IPOs of significant size and that are eligible for the MSCI Overseas China Equity Universe are considered for Early Inclusion in the MSCI Overseas China Index at the time of the IPO. More specifically, these securities must meet all the inclusion criteria described in Section 2 (except for the length of trading and liquidity requirements) and, in addition, must have a company full market capitalization that meet at least 1.8x the MSCI China Interim Market Standard Size-Segment Cutoff and a free float-adjusted market capitalization that meet at least 1.8x one-half of the MSCI China Interim Market Standard

Size-Segment Cutoff as of the first or second day of trading. If the decision is made to include an IPO early, the inclusion will generally become effective after the close of the security's tenth day of trading. However, in certain cases, another date may be chosen for the inclusion to reduce turnover, for example, where the normal inclusion date is close to the effective date of the next Index Review.

Securities may also be considered for early inclusion in other significant cases, including but not limited to those resulting from mergers and acquisitions giving rise to a large new company or a large primary or secondary public offering of an already listed security if the size of the offering exceeds the IPO threshold of 1.8 times one-half of the MSCI China Interim Market Standard Size-Segment Cutoff. Such cases will be treated in the same way as IPOs of significant size.

3.2.2 CHANGES IN SIZE-SEGMENT CLASSIFICATION AS A RESULT OF A LARGE CORPORATE EVENT

The Size-Segment classification of a security is reviewed simultaneously with the event, if the market capitalization change implied by the event, including potential update in the number of shares for the security, is deemed significant. A significant market capitalization change is defined as an increase of 50% or greater, or a decrease of 33% or more, relative to the company's full market capitalization before the event. The Size-Segment classification review will be based on the Interim Size-Segment Cutoffs used for the MSCI China Indexes.

3.2.3 DELETION OF EXISTING CONSTITUENTS

Existing constituents that are placed on the SGX's Watch List, delisted from a stock exchange, or companies that file for bankruptcy or file for protection from their creditors and/or are suspended and for which a return to normal business activity and trading is unlikely in the near future will be removed from the MSCI Overseas China Indexes as soon as practicable.

METHODOLOGY BOOK TRACKED CHANGES

The following sections have been modified since September 2011:

Section 3.1: Index Review

- Update first paragraph of section

Section 3.1.1: November and May Semi-Annual Index Reviews

- One paragraph added end of section

Section 3.1.2: February and August Quarterly Index Reviews

- One paragraph added end of section

Section 3.2.1: IPOs and Other Early Inclusions

- New section

The following sections have been modified since July 2014:

Section 2.2: Determining the Investable Equity Universe

- Added “except for large securities”
- Added Footnote 4

Section 2.3: Allocating

- Clarification on Foreign Inclusion Factor requirement for large securities

Section 3.1.3: Buffer Rules

- Clarification on conformity with Final Size-Segment Investability Requirements for existing constituents

The following sections have been modified since August 2014:

Section 3.1.4: Policy Regarding Trading Suspensions for Individual Securities during Index Reviews

- Added new section

The following sections have been modified since February 2017:

Section 3.1.4: Policy Regarding Trading Suspensions for Individual Securities during Index Reviews

- Updates

The following sections have been modified since September 2017:

Section 3.1.1: Cutoff Date for Market Capitalization and Prices Used for the Index Reviews

- Added new section

Section 3.1.6: Announcement Policy

- Added new section

Section 3.2: Ongoing Event-Related Maintenance

- Added clarification

Appendix

- Deleted

The following sections have been modified since September 2017:

Section 3.1.1: Cutoff Date for Market Capitalization and Prices Used for the Index Reviews

- Clarification added

The following sections have been modified since November 2018:

Section 2.1: Defining the Eligible Equity Universe

- Update first paragraph of section

CONTACT US

clientservice@msci.com

AMERICAS

Americas	1 888 588 4567 *
Atlanta	+ 1 404 551 3212
Boston	+ 1 617 532 0920
Chicago	+ 1 312 675 0545
Monterrey	+ 52 81 1253 4020
New York	+ 1 212 804 3901
San Francisco	+ 1 415 836 8800
São Paulo	+ 55 11 3706 1360
Toronto	+ 1 416 628 1007

EUROPE, MIDDLE EAST & AFRICA

Cape Town	+ 27 21 673 0100
Frankfurt	+ 49 69 133 859 00
Geneva	+ 41 22 817 9777
London	+ 44 20 7618 2222
Milan	+ 39 02 5849 0415
Paris	0800 91 59 17 *

ASIA PACIFIC

China North	10800 852 1032 *
China South	10800 152 1032 *
Hong Kong	+ 852 2844 9333
Mumbai	+ 91 22 6784 9160
Seoul	00798 8521 3392 *
Singapore	800 852 3749 *
Sydney	+ 61 2 9033 9333
Taipei	008 0112 7513 *
Thailand	0018 0015 6207 7181 *
Tokyo	+ 81 3 5290 1555

* = toll free

ABOUT MSCI

For more than 40 years, MSCI's research-based indexes and analytics have helped the world's leading investors build and manage better portfolios. Clients rely on our offerings for deeper insights into the drivers of performance and risk in their portfolios, broad asset class coverage and innovative research.

Our line of products and services includes indexes, analytical models, data, real estate benchmarks and ESG research.

MSCI serves 99 of the top 100 largest money managers, according to the most recent P&I ranking.

For more information, visit us at www.msci.com.

NOTICE AND DISCLAIMER

This document and all of the information contained in it, including without limitation all text, data, graphs, charts (collectively, the “Information”) is the property of MSCI Inc. or its subsidiaries (collectively, “MSCI”), or MSCI’s licensors, direct or indirect suppliers or any third party involved in making or compiling any Information (collectively, with MSCI, the “Information Providers”) and is provided for informational purposes only. The Information may not be modified, reverse-engineered, reproduced or disseminated in whole or in part without prior written permission from MSCI.

The Information may not be used to create derivative works or to verify or correct other data or information. For example (but without limitation), the Information may not be used to create indexes, databases, risk models, analytics, software, or in connection with the issuing, offering, sponsoring, managing or marketing of any securities, portfolios, financial products or other investment vehicles utilizing or based on, linked to, tracking or otherwise derived from the Information or any other MSCI data, information, products or services.

The user of the Information assumes the entire risk of any use it may make or permit to be made of the Information. NONE OF THE INFORMATION PROVIDERS MAKES ANY EXPRESS OR IMPLIED WARRANTIES OR REPRESENTATIONS WITH RESPECT TO THE INFORMATION (OR THE RESULTS TO BE OBTAINED BY THE USE THEREOF), AND TO THE MAXIMUM EXTENT PERMITTED BY APPLICABLE LAW, EACH INFORMATION PROVIDER EXPRESSLY DISCLAIMS ALL IMPLIED WARRANTIES (INCLUDING, WITHOUT LIMITATION, ANY IMPLIED WARRANTIES OF ORIGINALITY, ACCURACY, TIMELINESS, NON-INFRINGEMENT, COMPLETENESS, MERCHANTABILITY AND FITNESS FOR A PARTICULAR PURPOSE) WITH RESPECT TO ANY OF THE INFORMATION.

Without limiting any of the foregoing and to the maximum extent permitted by applicable law, in no event shall any Information Provider have any liability regarding any of the Information for any direct, indirect, special, punitive, consequential (including lost profits) or any other damages even if notified of the possibility of such damages. The foregoing shall not exclude or limit any liability that may not by applicable law be excluded or limited, including without limitation (as applicable), any liability for death or personal injury to the extent that such injury results from the negligence or willful default of itself, its servants, agents or sub-contractors.

Information containing any historical information, data or analysis should not be taken as an indication or guarantee of any future performance, analysis, forecast or prediction. Past performance does not guarantee future results.

The Information should not be relied on and is not a substitute for the skill, judgment and experience of the user, its management, employees, advisors and/or clients when making investment and other business decisions. All Information is impersonal and not tailored to the needs of any person, entity or group of persons.

None of the Information constitutes an offer to sell (or a solicitation of an offer to buy), any security, financial product or other investment vehicle or any trading strategy.

It is not possible to invest directly in an index. Exposure to an asset class or trading strategy or other category represented by an index is only available through third party investable instruments (if any) based on that index. MSCI does not issue, sponsor, endorse, market, offer, review or otherwise express any opinion regarding any fund, ETF, derivative or other security, investment, financial product or trading strategy that is based on, linked to or seeks to provide an investment return related to the performance of any MSCI index (collectively, “Index Linked Investments”). MSCI makes no assurance that any Index Linked Investments will accurately track index performance or provide positive investment returns. MSCI Inc. is not an investment adviser or fiduciary and MSCI makes no representation regarding the advisability of investing in any Index Linked Investments.

Index returns do not represent the results of actual trading of investable assets/securities. MSCI maintains and calculates indexes, but does not manage actual assets. Index returns do not reflect payment of any sales charges or fees an investor may pay to purchase the securities underlying the index or Index Linked Investments. The imposition of these fees and charges would cause the performance of an Index Linked Investment to be different than the MSCI index performance.

The Information may contain back tested data. Back-tested performance is not actual performance, but is hypothetical. There are frequently material differences between back tested performance results and actual results subsequently achieved by any investment strategy.

Constituents of MSCI equity indexes are listed companies, which are included in or excluded from the indexes according to the application of the relevant index methodologies. Accordingly, constituents in MSCI equity indexes may include MSCI Inc., clients of MSCI or suppliers to MSCI. Inclusion of a security within an MSCI index is not a recommendation by MSCI to buy, sell, or hold such security, nor is it considered to be investment advice.

Data and information produced by various affiliates of MSCI Inc., including MSCI ESG Research LLC and Barra LLC, may be used in calculating certain MSCI indexes. More information can be found in the relevant index methodologies on www.msci.com.

MSCI receives compensation in connection with licensing its indexes to third parties. MSCI Inc.’s revenue includes fees based on assets in Index Linked Investments. Information can be found in MSCI Inc.’s company filings on the Investor Relations section of www.msci.com.

MSCI ESG Research LLC is a Registered Investment Adviser under the Investment Advisers Act of 1940 and a subsidiary of MSCI Inc. Except with respect to any applicable products or services from MSCI ESG Research, neither MSCI nor any of its products or services recommends, endorses, approves or otherwise expresses any opinion regarding any issuer, securities, financial products or instruments or trading strategies and MSCI’s products or services are not intended to constitute investment advice or a recommendation to make (or refrain from making) any kind of investment decision and may not be relied on as such. Issuers mentioned or included in any MSCI ESG Research materials may include MSCI Inc., clients of MSCI or suppliers to MSCI, and may also purchase research or other products or services from MSCI ESG Research. MSCI ESG Research materials, including materials utilized in any MSCI ESG Indexes or other products, have not been submitted to, nor received approval from, the United States Securities and Exchange Commission or any other regulatory body.

Any use of or access to products, services or information of MSCI requires a license from MSCI. MSCI, Barra, RiskMetrics, IPD, and other MSCI brands and product names are the trademarks, service marks, or registered trademarks of MSCI or its subsidiaries in the United States and other jurisdictions. The Global Industry Classification Standard (GICS) was developed by and is the exclusive property of MSCI and Standard & Poor’s. “Global Industry Classification Standard (GICS)” is a service mark of MSCI and Standard & Poor’s.